



## Oil Majors' Structural Requirements for Newbuild Tankers and Trading Vessels

**James Collett – Naval Architect  
BP Shipping**

While the material given in these papers has been developed from the information currently available, it is intended purely as general guidance only to be used at the user's own discretion. Although this material is available, the material is not a substitute for proper engineering analysis, or the text of any law, treaty, convention or technical or reference material referred to. When the material is used by anyone a user has to indicate the source of materials. No responsibility is accepted by the Tanker Structure Co-Operative Forum, or by any person, firm, corporation, or organization who or which has been in any way concerned with furnishing of information or data, the compilation and publication of these papers.

## Newbuilds – Global Strength



- 10% margin above max design condition

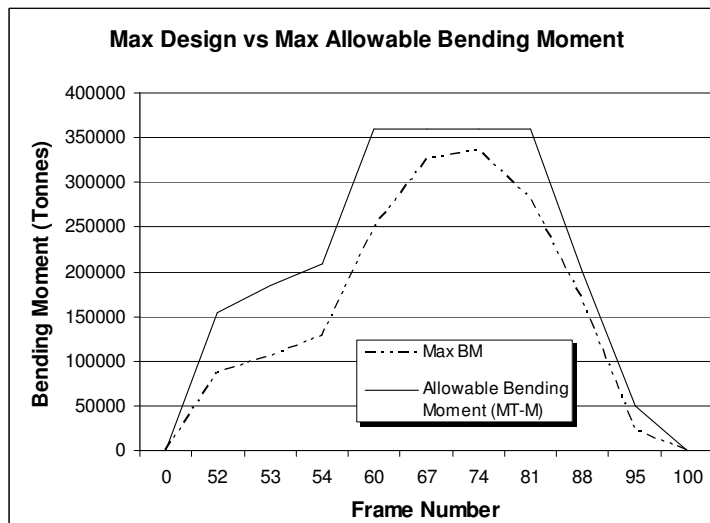

# Newbuilds – Global Strength



- 10% margin above max design condition
- Additional loading conditions

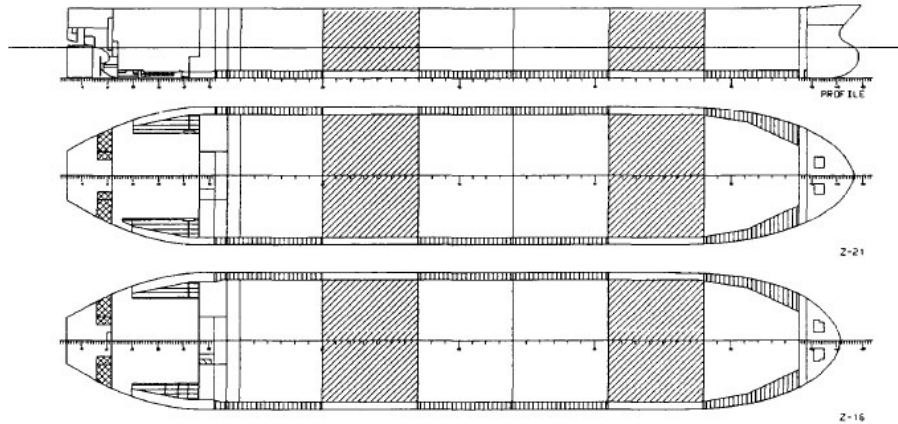

 raising the flag together  
clean seas ■ safe ships ■ commercial success

# Newbuilds – Global Strength



- 10% margin above max design condition
- Additional loading conditions
- Enhanced Fatigue Life



 raising the flag together  
clean seas ■ safe ships ■ commercial success

# Newbuilds – Global Strength



- 10% margin above max design condition
- Additional loading conditions
- Enhanced Fatigue Life

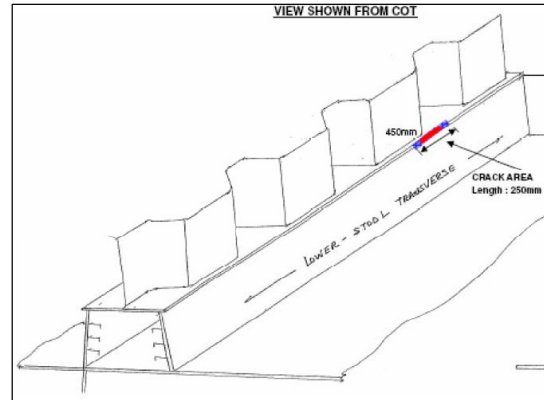
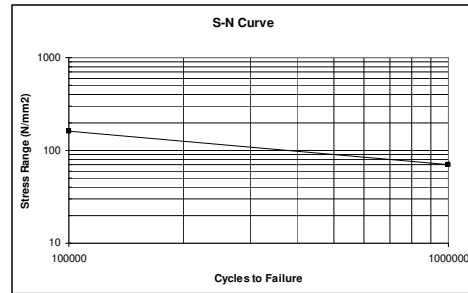

# Newbuilds – Design Details & Materials



- Symmetrical Sections and soft nosed pillar stiffeners

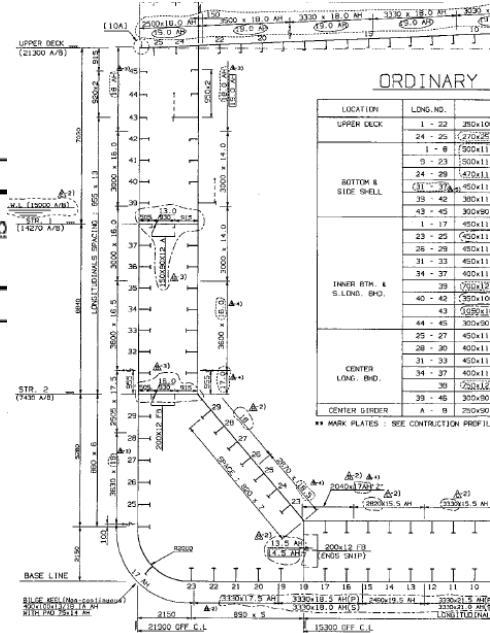
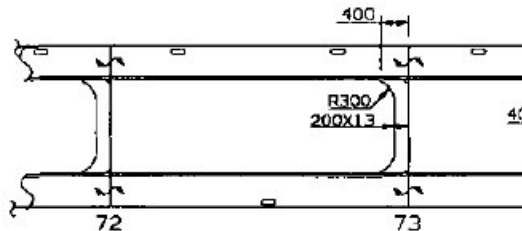

# Newbuilds – Design Details & Materials



- Bracket Design

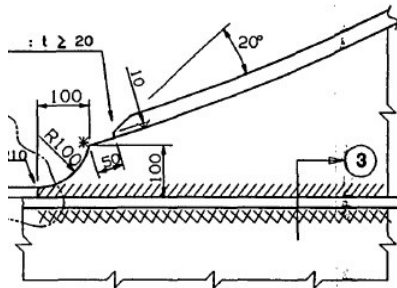

FACE PLATE TAPERING DETAIL

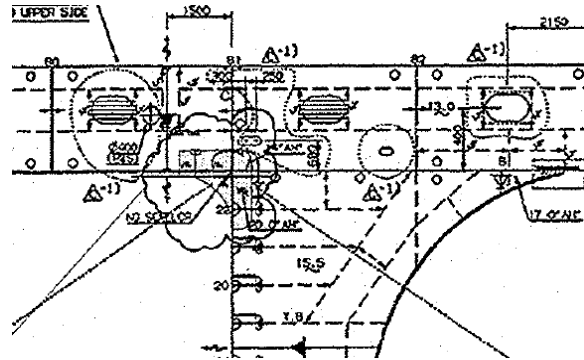
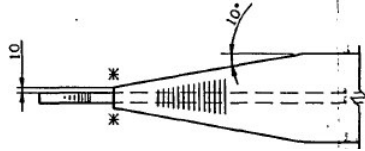

raising the flag together  
clean seas ■ safe ships ■ commercial success

# Newbuilds - Construction



- Full penetration welding

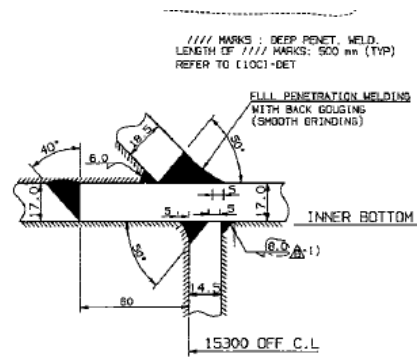
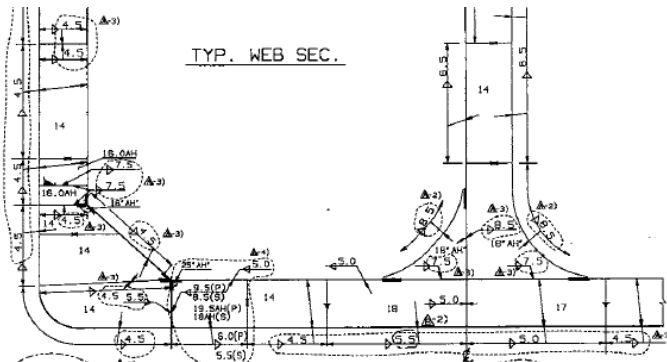

raising the flag together  
clean seas ■ safe ships ■ commercial success

## Newbuilds - Construction



- Full penetration welding
- NDT requirements



## Newbuilds - Construction



- Full penetration welding
- NDT requirements
- Corrosion prevention



# Vetting of Third Party Tonnage



raising the flag together  
 clean seas ■ safe ships ■ commercial success

# Vetting - SIRE

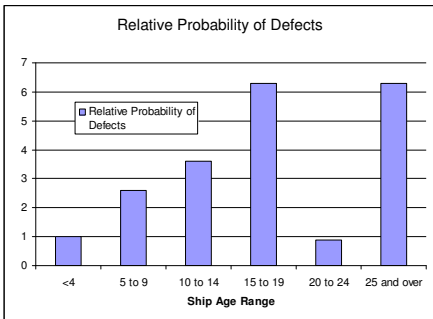
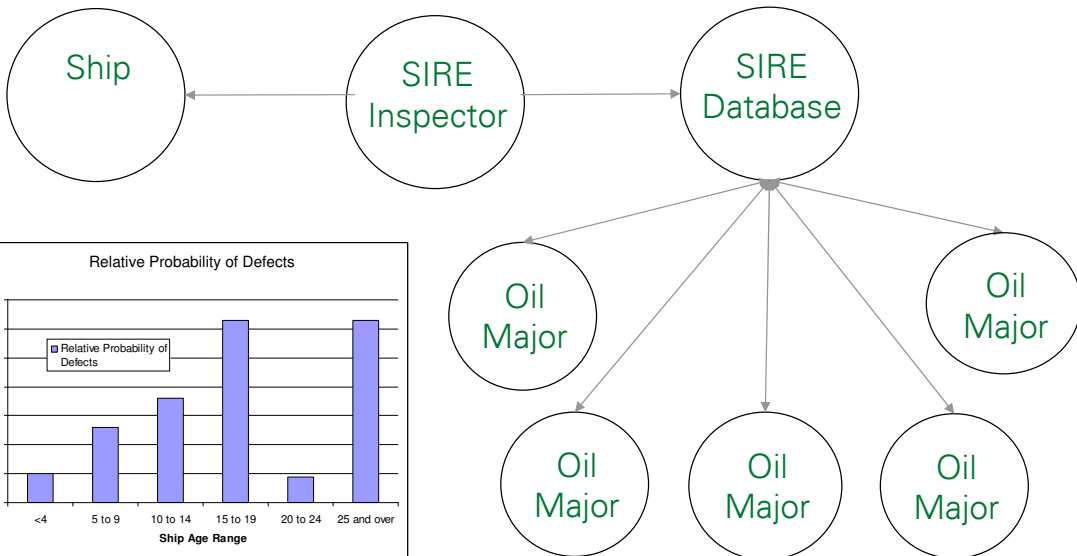

raising the flag together  
 clean seas ■ safe ships ■ commercial success

# Vetting - CAP

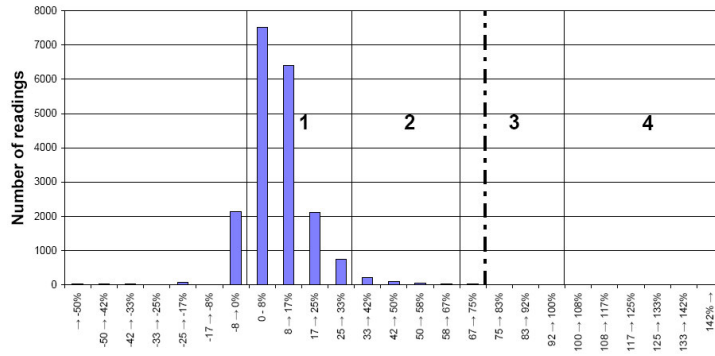
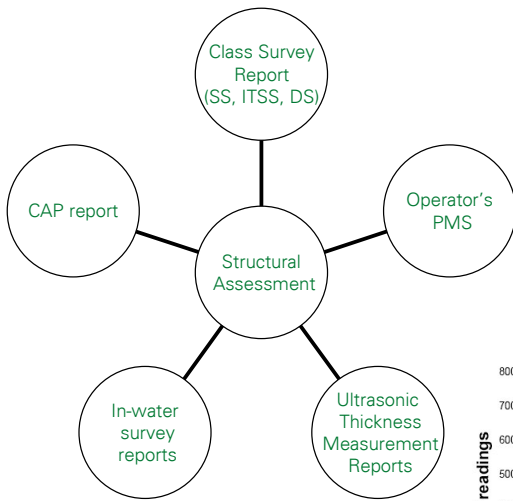

raising the flag together  
 clean seas ■ safe ships ■ commercial success